

Watkins Manufacturing Corporation

INSTALLATION

Of your **ProLift® III**

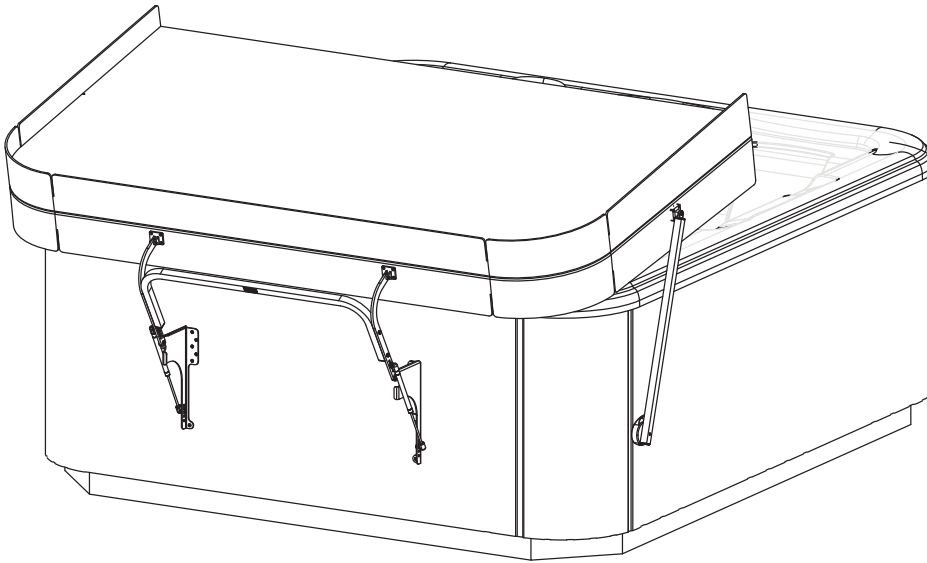

TABLE OF CONTENTS

INSTALLATION REQUIREMENTS..... 1	PROLIFT III INSTALLATION..... 5
KIT INCLUDES	ATTACH CROSSLINK ASSY
INSTALLATION REQUIREMENTS..... 2	PROLIFT III INSTALLATION..... 6
TOOLS REQUIRED	ATTACH SIDE ARM ASSY
IMPORTANT INFORMATION	ALIGN SIDE ARM ASSY
PROLIFT III INSTALLATION PREPARATION 3	PROLIFT III INSTALLATION..... 7
INSTALL PREPARATION	INSTALL GAS SPRING
LOCATE PLATES	ADJUST GAS SPRING
PROLIFT III INSTALLATION..... 4	
ATTACH BACK HINGES	
ATTACH SIDE HINGES	
ASSEMBLE CROSSLINK	

USED IN KIT # 74919)

INSTALLATION REQUIREMENTS

KIT INCLUDES

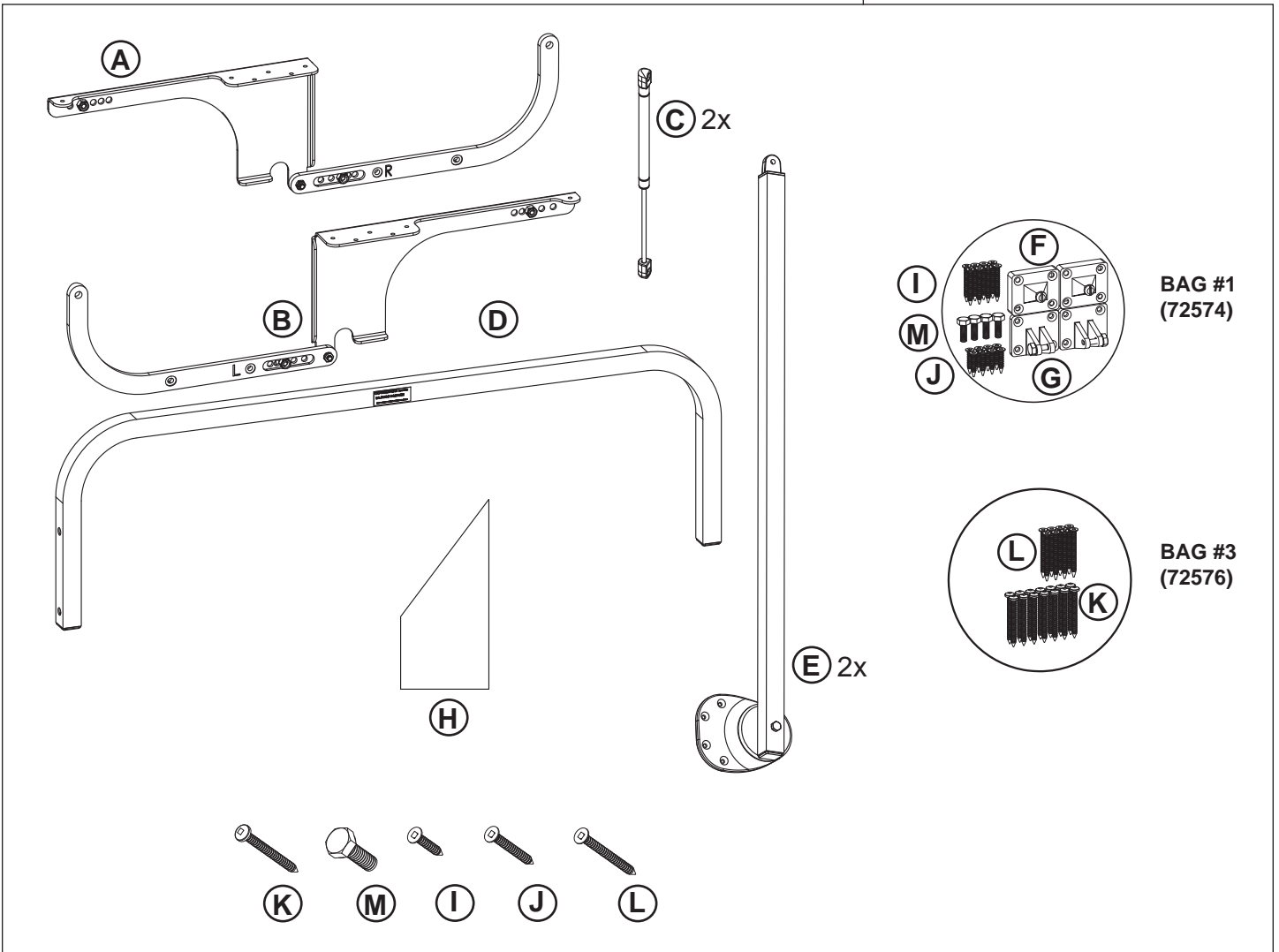

PART	QUANTITY	DESCRIPTION	PART	QUANTITY	DESCRIPTION
A	1	Pivot Assembly, Right (72570)	H	1	Template
B	1	Pivot Assembly, Left (72571)	I	8	#10 x 1" Square Flat Head (Bag 1)
C	2	Gas Spring (71095)	J	8	#10 X 1½" Square Flat Head (Bag 1&2)
D	1	Crosslink Assembly (72572)	K	12	#10 X 2" Square Pan Head (Bag 3)
E	2	Side Arm Assembly (72573)	L	8	#10 X 2" Square Flat Head (Bag 3)
F	2	Side Hinge with Screw (Bag 1)	M	4	¼-20 x ¾" Hex Bolt (Bag 1)
G	2	Back Hinge with Screw (Bag 1)			

INSTALLATION REQUIREMENTS

TOOLS REQUIRED

Cordless Drill



Flat Head Screwdriver



7/16" Socket with Ratchet



#2 Square Drive Bit



7/64 and 1/8" Drill Bits



Fine Tip Marker



1/2" Wrench



IMPORTANT INFORMATION

- Read all of the instructions thoroughly before performing this installation.
- There must be a minimum of 24" clearance between the wall and the retracting side of the spa for cover to operate properly and 4" on each side for Side Arm clearance.
- The Warning Label on the cover is always the front of the cover, the lifter will attach to the opposite side (retracting side) where the entire cover will fold down into when installed.
- To ensure that the cover seals correctly, the spa must be level.

PROLIFT III INSTALLATION PREPARATION

STEP 1 INSTALL PREPARATION

1. Determine the placement of the cover:
 - See Figure 1.1.
 - When the spa uses a side to side configuration the cover can fold in either direction, however, the side with the Warning Label will always fold over to the side without the label.

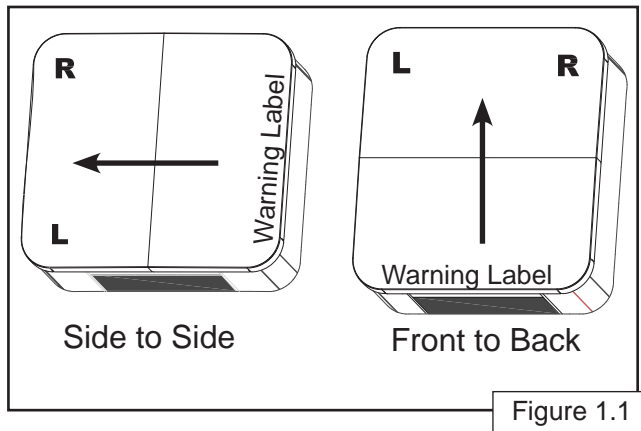

2. Align the cover:
 - The Warning Label must be facing the front of the spa (front to back) or the right side if folding to the left of the spa (side to side) (Figure 1.2) or to the left side if folding the cover to the right.
 - Align the back or side of the cover (opposite side of Warning Label) with the back or side of the spa skirt (Figure 1.2).

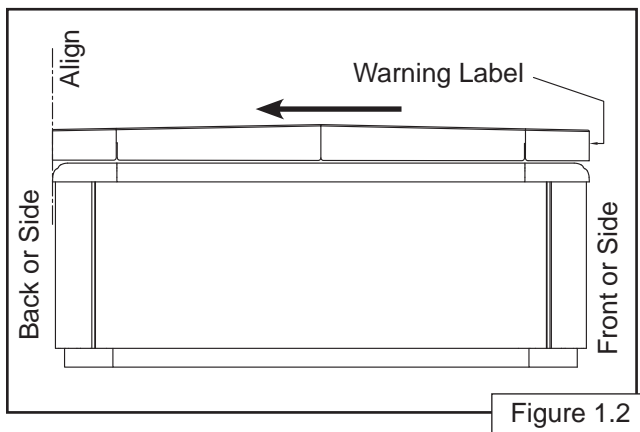

STEP 2 LOCATE PLATES

Every Watkins cover has 6 aluminum plates installed into the foam core hidden beneath the vinyl on 3 sides of the cover. There are two plates on the opposite side of the Warning Label and two on each side of the cover (Figure 1.3).

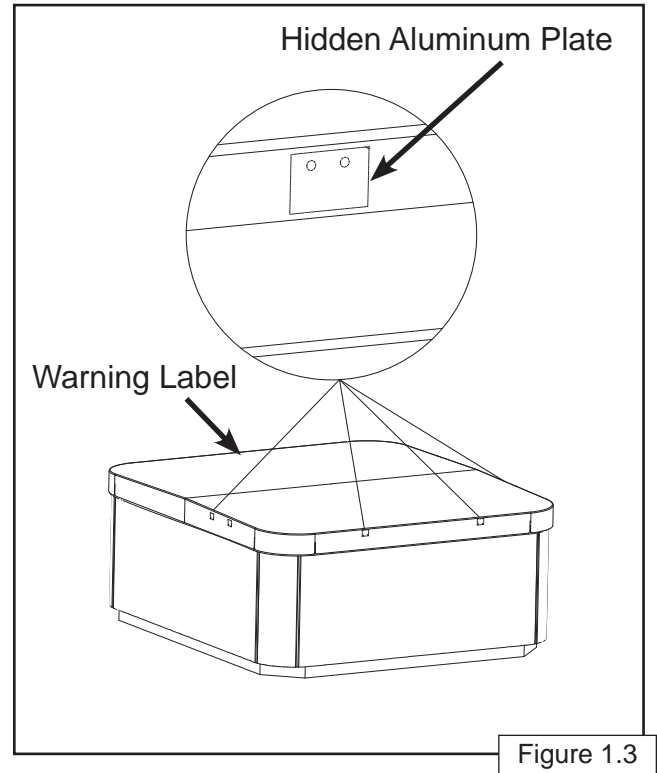

Only the hidden aluminum plate closest to the middle of the cover on each side is used for this cover lifter as well as the two plates in the back opposite the Warning Label.

There are two predrilled holes on the top of each plate. Feel around the side of the cover to find the holes in the plates. Use a fine tip marker to mark the center of the hole for each of the four plates that will be used (Figure 1.3).

PROLIFT III INSTALLATION

STEP 1 ATTACH BACK HINGES

Locate Bag #1, some of the contents will be used to fasten the Rear Hinges.

REAR HINGES:

Line up the top Rear Hinge holes (Figure 2.1G) with 2 of the marked holes on the back side of the cover. Using the cordless drill and square drive bit fasten the Rear Hinge to the cover by using two of the #10 x 1"square (I) Flat Head screws on the top (marked) holes first. Using the 1/8" drill bit and the bottom two holes of the Rear Hinge, drill through the hidden aluminum plate followed by inserting two more of the same screws in the bottom holes. Repeat procedure for second Rear Hinge.

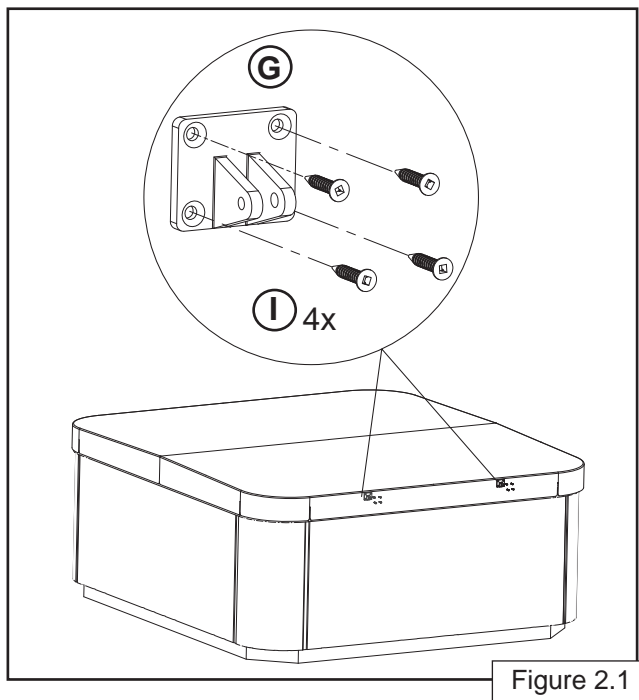

Figure 2.1

STEP 2 ATTACH SIDE HINGES

Locate Bag #1, some of the contents will be used to fasten the Side Hinges.

SIDE HINGES:

Line up the top Side Hinge holes (Figure 2.2F) with 2 of the marked holes on one side of the cover. Using the cordless drill and square drive bit fasten the Side Hinge to the cover by

using two of the #10 x 1½"square (J) Flat Head screws on the top (marked) holes first. Using the 1/8" drill bit and the bottom two holes of the Side Hinge, drill through the hidden aluminum plate followed by inserting two more of the same screws in the bottom holes. Repeat procedure for Side Hinge on opposite side of the cover.

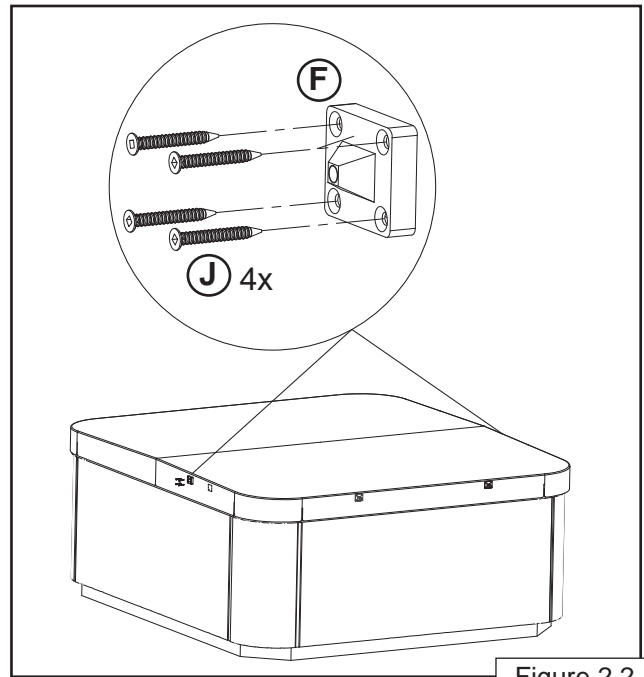

Figure 2.2

STEP 3 ASSEMBLE CROSSLINK

1. Locate the Right & Left Pivot Assemblies, Crosslink and (4) ¼"-20 Hex Bolts (Figure 3.1).

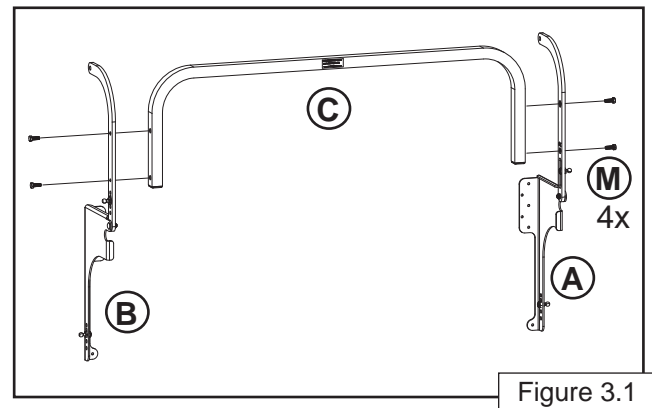

Figure 3.1

2. Orient (Figure 3.1) on floor and attach A and B to C using (4) ¼"-20 Hex Bolts (M).

PROLIFT III INSTALLATION

STEP 4 ATTACH CROSSLINK ASSY

1. Unscrew Pan Head Screws attached to the Rear Hinges (Figure 4.1 G).

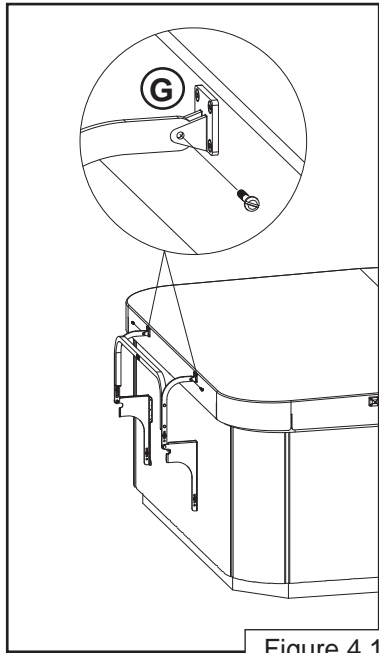

Figure 4.1

Align both Pivot Assemblies (attached to the Crosslink assembly) inside the Rear Hinges and fasten using the two Pan Head Screws (Figure 4.1).

For the following steps on Utopia Spas(2016-Current), please go to page 9 at the end of this document.

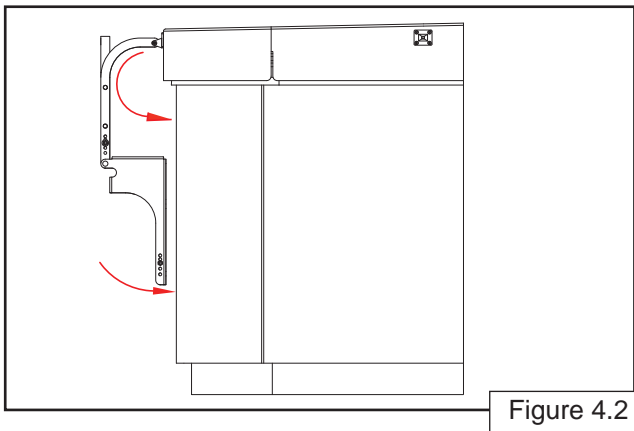

Figure 4.2

Rotate Pivot Assemblies until the bottom (Mounting Bracket) touch the side of the spa (Figure 4.2).

- IMPORTANT:** Carefully examine cover to be sure it is still aligned evenly with the outside edges of the spa bartop (Figure 1.2).
2. Using the Mounting Bracket (bottom part of the Pivot Assembly) as a template, predrill 1/8" holes into the back of the spa (Figure 4.3) with 1/2" max. depth. There are (6) holes per Mounting Bracket.

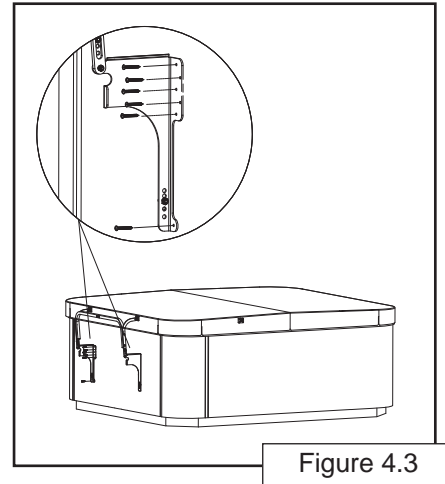

Figure 4.3

Secure the Mounting Bracket to the spa cabinet using (12) of the Pan Head Screws (Figure 4.4).
Bag # 3 (K) (#10 2" Pan Head screws)

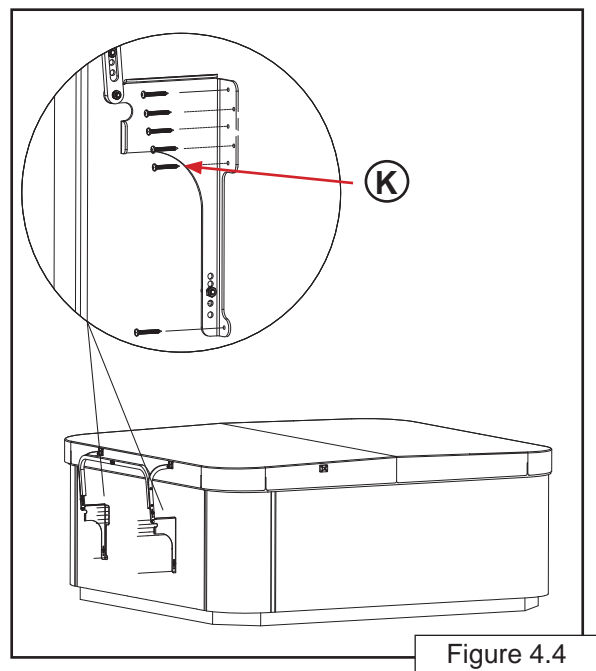

Figure 4.4

PROLIFT III INSTALLATION

STEP 5 ATTACH SIDE ARM ASSY

Remove the single bolt attached to the Side Hinge (Figure 5.1F) on the side of the spa. Attach the Side Arm Assembly (Figure 5.1E) to the Side Hinge (Figure 5.1F) using the single bolt. Repeat on other side of spa.

IMPORTANT: Plastic Bottom (Pivot Bracket) of Side Arm Assembly (E) must lay flat against spa siding. **DO NOT OVERTIGHTEN SCREW** or the cover will bind.

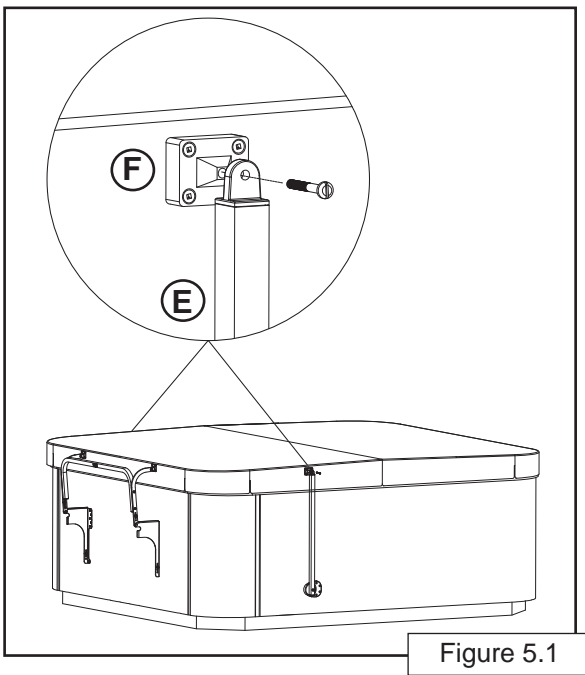

STEP 6 ALIGN SIDE ARM ASSY

Locate the Cardboard Template (H) and place on ground below Side Arm Assembly (Figure 6.1).

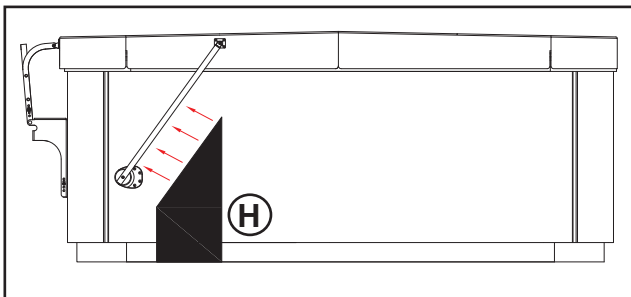

Slide Template against Side Arm Assembly making sure the entire angle of the Template touches the Side Arm Assembly (Figure 6.1)

Position the Plastic Bottom (Pivot Bracket) (E) with the holes facing away from the back of the cover (Figure 6.2).

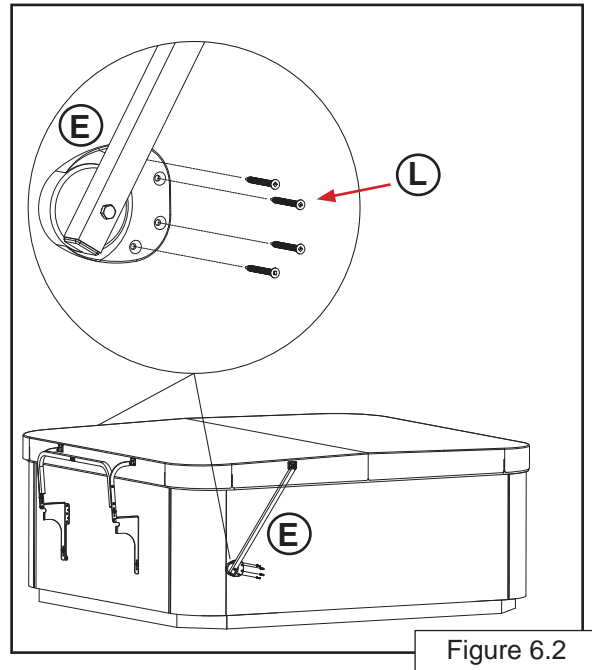

Secure the Side Arm Assembly (E) to the spa cabinet using (4) of the Flat Head Screws per Side Arm Assembly (Figure 6.2). Bag # 3 (L) (#10 2" screws)

REPEAT ALIGNMENT ON OTHER SIDE - Make sure both Side Arms angle toward the back of cover.

PROLIFT III INSTALLATION

STEP 7 INSTALL GAS SPRING

1. Locate the Gas Springs (C) and snap onto the upper ball stud (attached to the Pivot Arm Assembly) with the barrel end of the Gas Spring up on both sides (Figure 7.1).

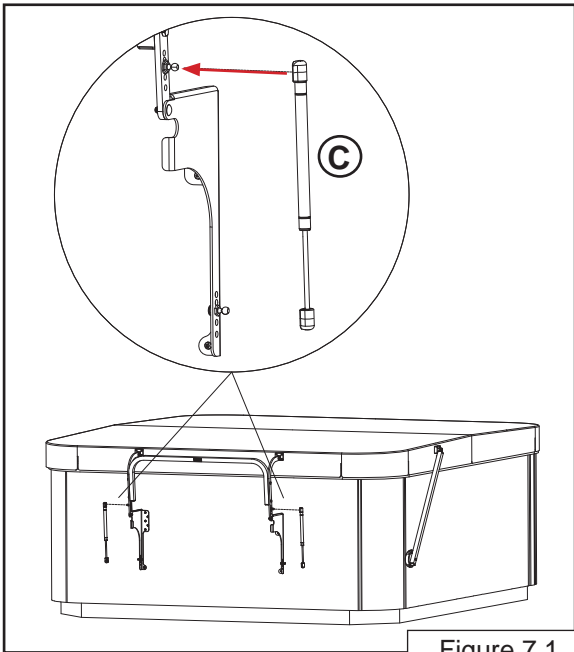

Figure 7.1

2. Fold Cover in half and pull to position shown (Figure 7.2). Snap the lower joint of the Gas Springs onto the lower ball stud (Figure 7.2).

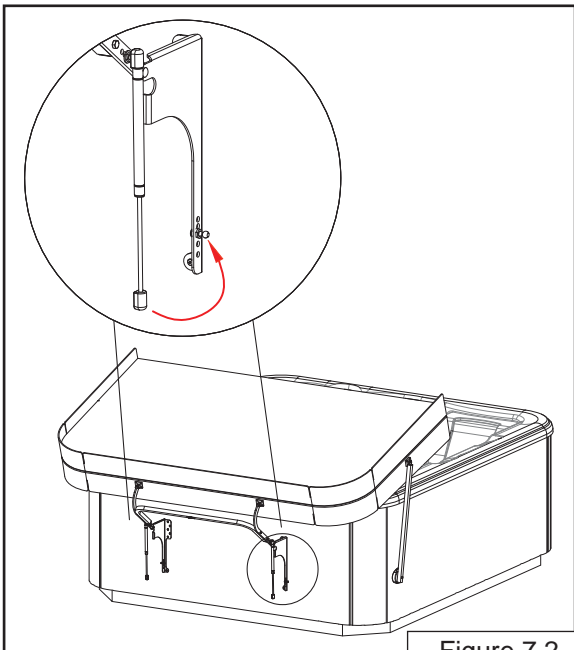

Figure 7.2

STEP 8 ADJUST GAS SPRING

The motion of the cover when opening should be controlled and smooth rotating to a gentle stop. If this is how your cover works, skip this step. If the cover does not fully open or the cover does not come to a gentle rest then do the following:

- a. Remove both Gas Springs by reversing the order in Step 7. Remove Gas Springs from each ball studs by placing a flat blade screwdriver behind the retaining cup (hold up the clip with the screwdriver) and pull Gas Spring away.
- b. Remove both lower ball studs with a $\frac{1}{2}$ " wrench. Raise or lower ball studs one hole (Figure 8.1)
- c. Remove both upper ball studs with a $\frac{1}{2}$ " wrench. Move ball studs in the same direction as in step b.

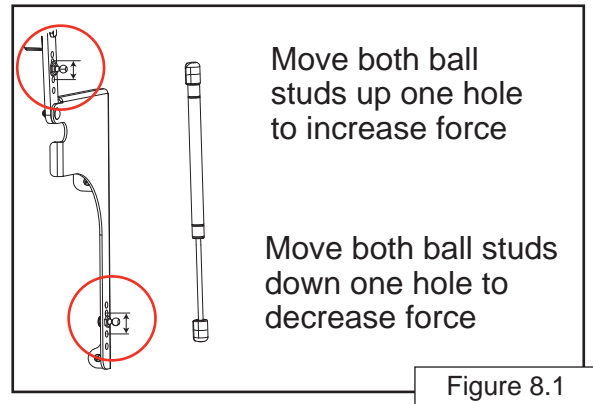

Figure 8.1

- d. Repeat Step 7

HOW TO OPEN AND CLOSE COVER

Push on either side of the cover to open or close (Figure 8.2). Cover should come to a gentle rest with a slight tilt towards the spa.

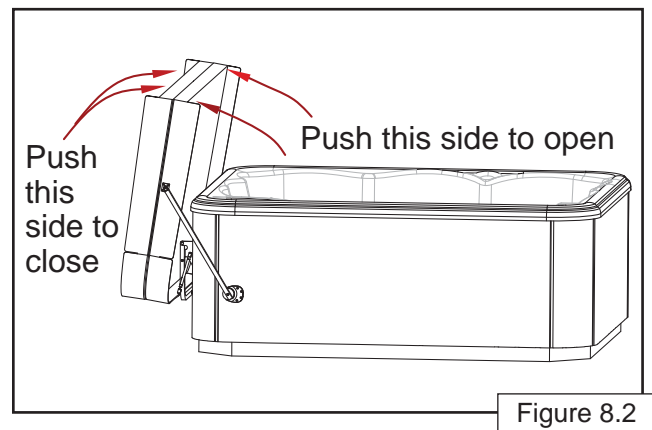
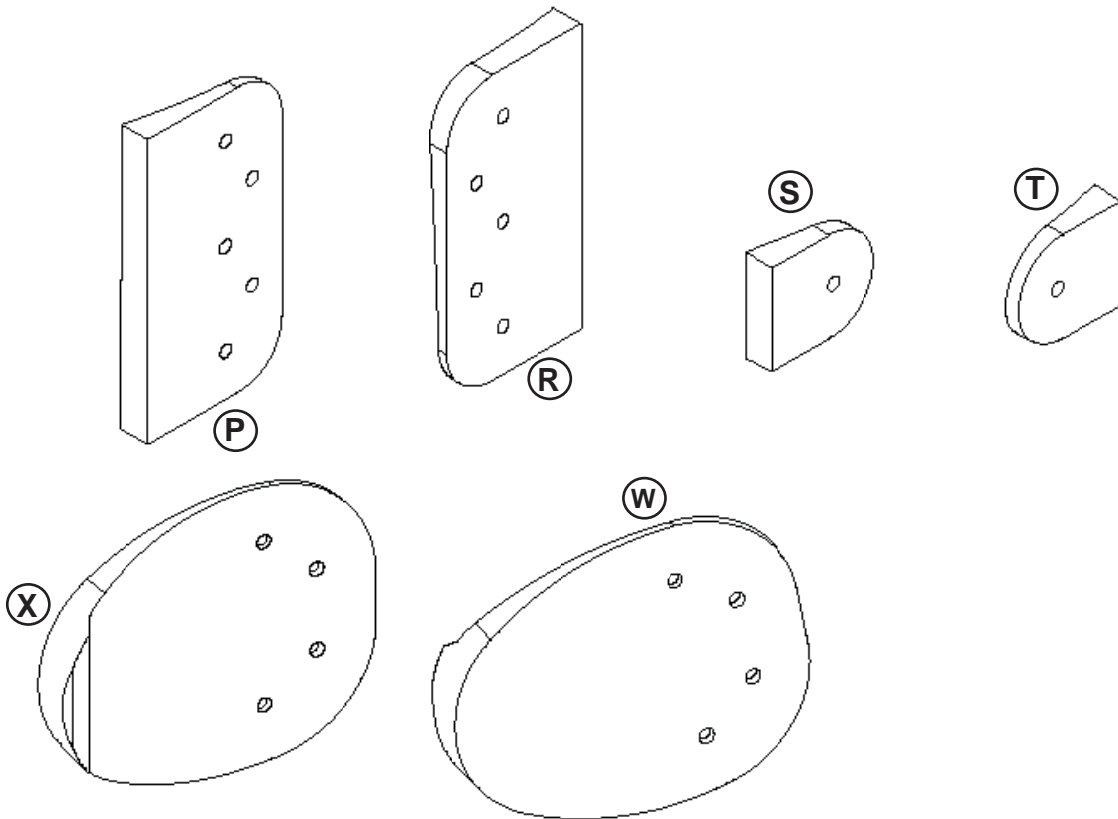

Figure 8.2

Watkins Manufacturing Corporation

INSTALLATION

Of the **PROLIFT® III Spacers**
UTOPIA® SPAS ONLY (2016-CURRENT)



PART	QUANTITY	DESCRIPTION
P	1	Top Mounting Bracket Spacer, Left
R	1	Top Mounting Bracket Spacer, Right
S	1	Bottom Mounting Bracket Spacer, Left
T	1	Bottom Mounting Bracket Spacer, Right
W	1	Side Pivot Bracket Spacer, Right
X	1	Side Pivot Bracket Spacer, Left

(INTENDED FOR KITS: 77700, 77703, 77706)

MOUNTING BRACKET SPACER INSTALLATION

STEP 1

ALIGN MOUNTING BRACKET WITH SPA

Rotate Pivot Assemblies until the bottom (Mounting Bracket) touches the side of the spa (Figure 1.1).

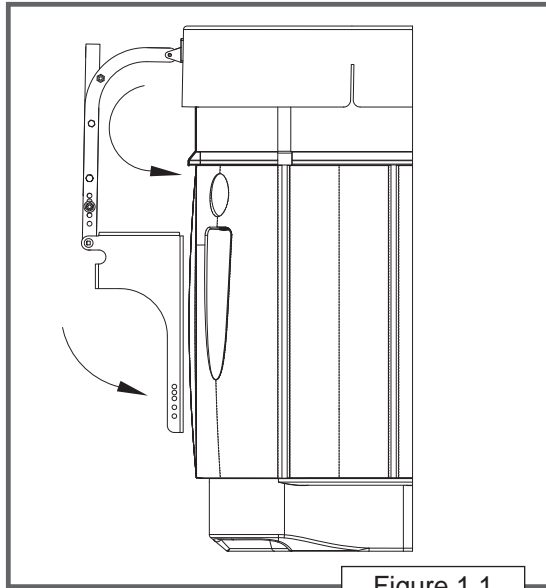

Figure 1.1

STEP 2

DRILL HOLES INTO SPA

Using the Mounting Bracket (bottom part of the Pivot Assembly) as a template. Pre-drill $7/64$ " holes into spa (Figure 1.2) with 1" max. depth. There are (6) holes per Mounting Bracket.

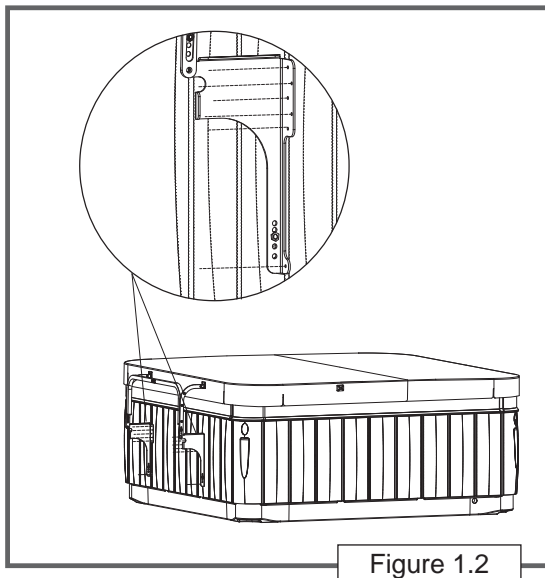

Figure 1.2

STEP 3

SECURE MOUNTING BRACKETS & SPACERS TO SPA

Making sure to align the holes on the bracket to the holes on the spacers (R)&(T), secure the mounting bracket and spacers (R) & (T) to the spa cabinet using (12) of the Pan Head Screws (K) (Figure 1.3). Bag # 3 (K) (#10 2" Pan Head screws).

IMPORTANT: Make sure holes are facing towards the middle of the spa.

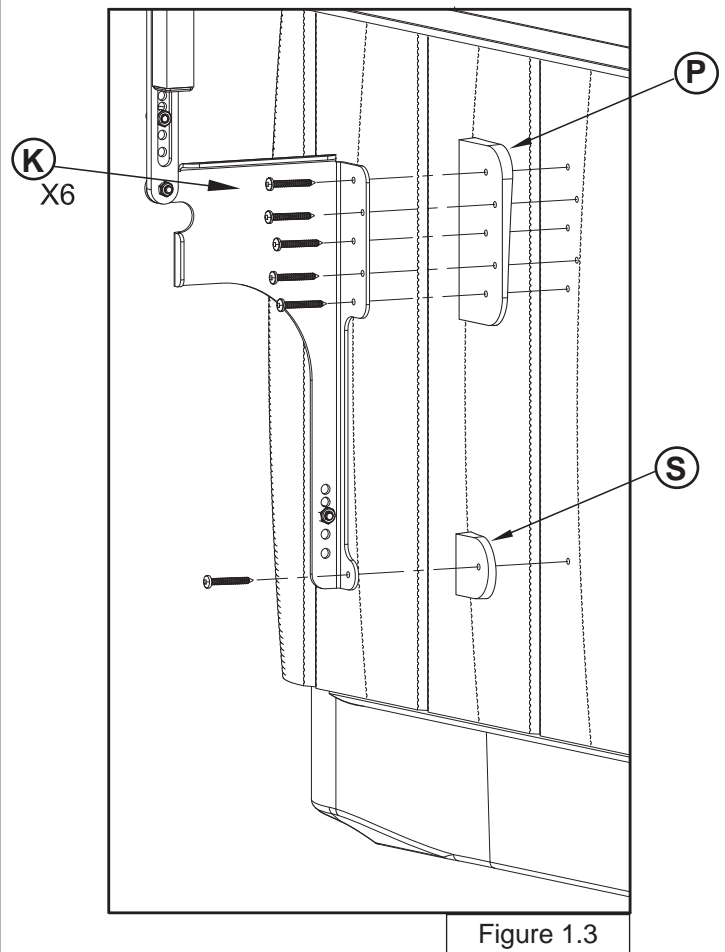

Figure 1.3

PIVOT BRACKET SPACER INSTALLATION

STEP 1 ALIGN SIDE ARM ASSY.

Locate the Template with 46° printed on it and place on ground below Side Arm Assembly (Figure 2.1).

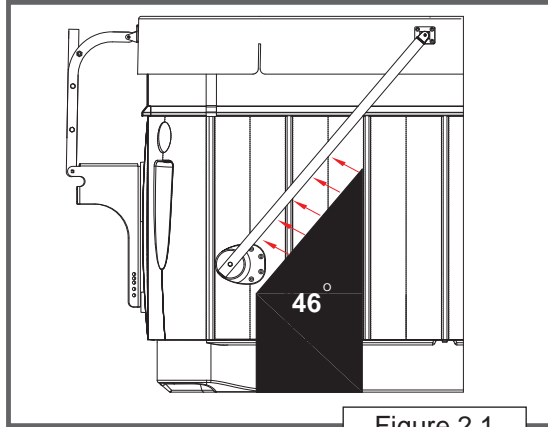

Figure 2.1

Slide Template against Side Arm Assembly making sure the entire angle of the Template touches the Side Arm Assembly (Figure 2.1)

STEP 2 DRILL HOLES INTO SPA

Position W or X Side Spacer against Pivot Bracket E, and insert two screws (L) from the back. Then position arm so rib of side spacer fits into appropriate groove. Predrill 7/64" holes into the spa (Figure 2.2) with 1" max. depth. There are (4) holes per Pivot Bracket.

Position the Plastic Bottom (Pivot Bracket) (E) with the holes facing toward the middle of the spa (Figure 2.2).

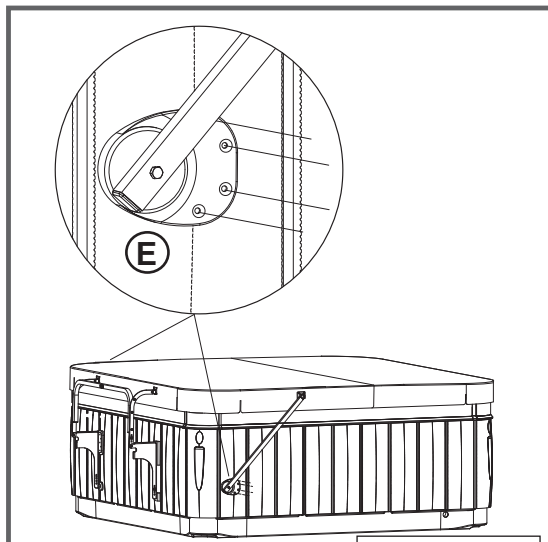

Figure 2.2

STEP 3 SECURE PIVOT BRACKETS & SPACERS TO SPA

Remove the two screws (L) from the back of W or X. Making sure that the holes on Spacer (W) align with Bracket (E), secure bracket and Spacer (W) to spa using 4 Flat head Screws (L) (Figure 2.3). Bag # 3 (L) (#10 2" Flat Head screws).

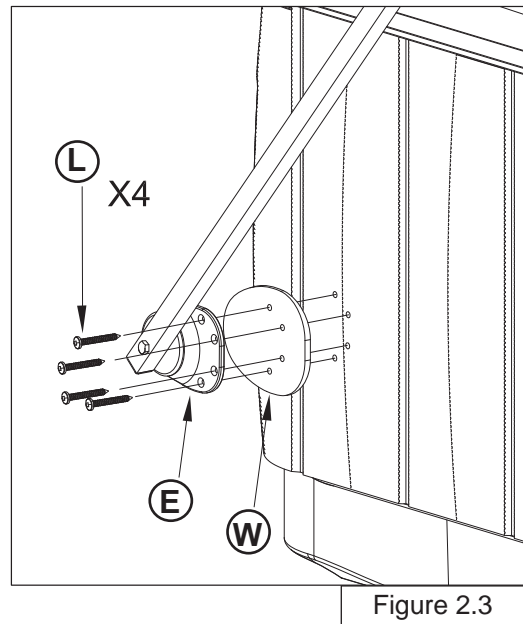

Figure 2.3

Important: Make sure that the Spacer (W) back end fits into the vertical groove between the corner and side panel.(Figure 2.4)

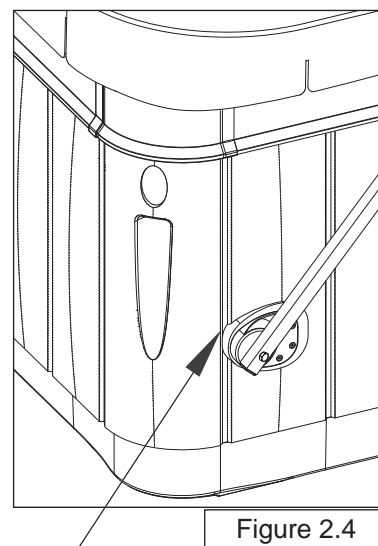

Figure 2.4